

VG SERIES

產品特點 Product Features

65dB

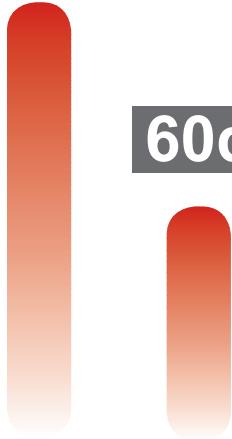

60dB

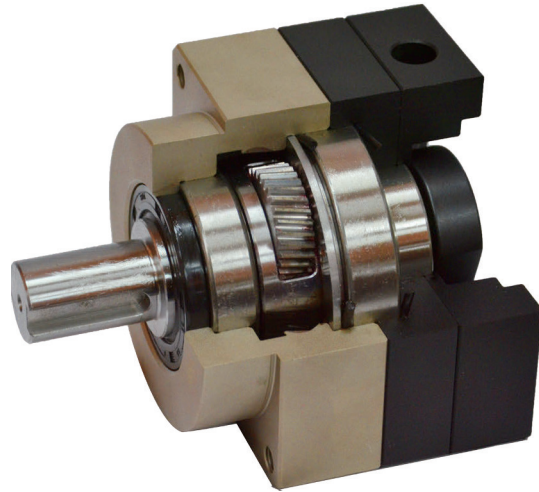

採日式規格、體積較短、低噪音
Use Japanese specification
Small in size

減速機結構採螺旋齒輪設計，齒形嚙合率為一般正齒輪的二倍以上，具有運轉平順、低噪音高輸出扭矩和低背隙的特性。
Adopting helical gear design, the contact ratio of planetary reducer is twice higher than vertical one. Smooth running, high output torque and low backlash are distinguished features.



輸入端與馬達的連結機構，採用筒夾式的鎖緊經動平衡分析，以確保在高輸入轉速下結合介面的同心度和零背隙的動力傳遞。

Triple split collet with dynamic balanced set collar clamping system provides backlash free power transmission and eliminates slippage. 100% concentricity allows for smooth rotation and higher input speed capability.



行星臂架與輸出軸採一體式的設計結構，確保最大耐扭力剛性及穩定性。

Integrated design of planet carrier and output shaft ensures the maximum torque stiffness and stability.



齒輪箱和內環齒輪採一體式設計，結構緊湊、精密度高、輸出扭矩大。

Gear box and internal ring gear are integrated designed, diameter maximized, high precision and high torque capacity are specialties.

MODEL : VG78 SERIES

1-Stage (Ratio: 3~10)

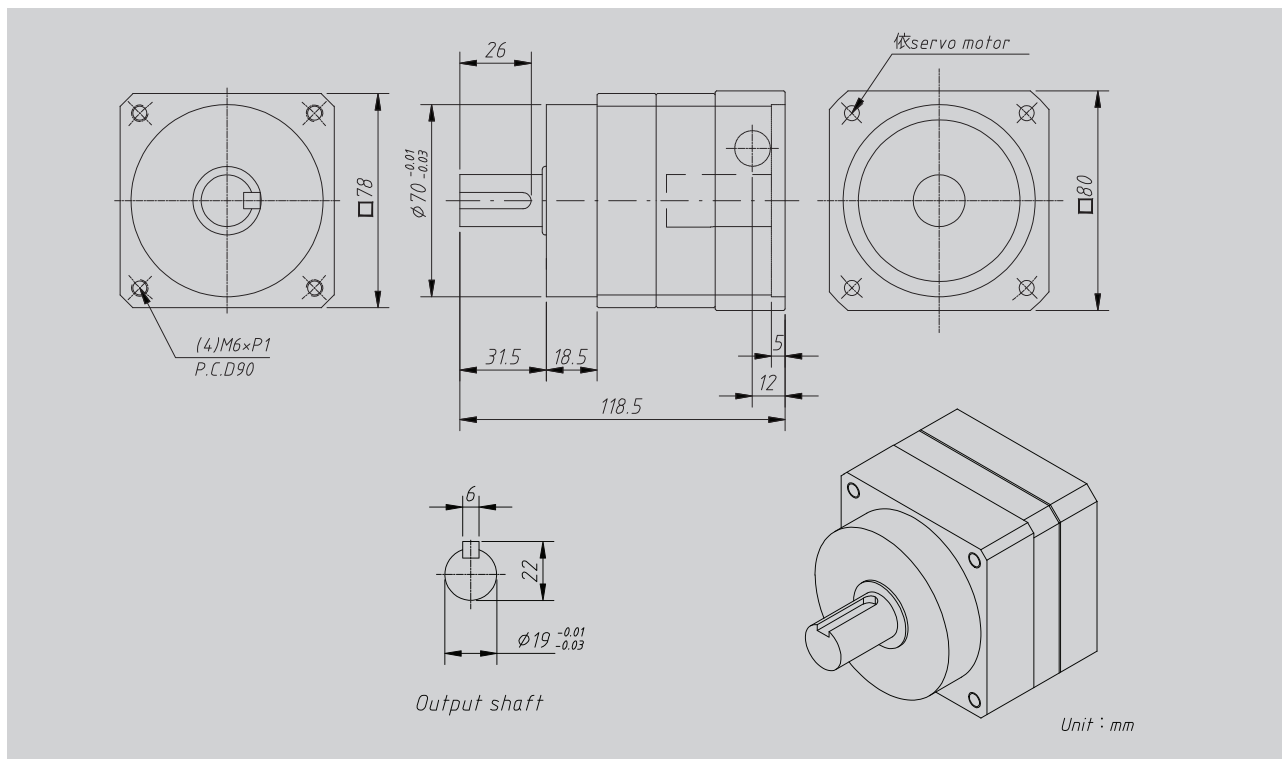

減速比 Ratio	3	4	5	6	7	8	9	10
額定輸出力矩 Nominai Output Torque (N.m)	55	50	48	45	46	45	44	43
最大輸入轉速 Max. input Speed	10000 rpm							
額定輸入轉速 Nominal input Speed	5000 rpm							
標準背隙 Standard Backlash	≤ 7 arcmin							
急停扭矩 Emergency Stop Torque	3 倍額定輸出力矩 /3Time Of Nominal Output Torque							
扭轉剛性 Torsional Rigidity	7 Nm							
容許徑向力 Max. Radial Force	1250 N							
容許軸向力 Max. Axial Force	660 N							
使用壽命 Service Life	20000 hr							
使用溫度 Operating Temp	-25°C ~ 90°C							
效率 Efficiency	≥ 97%							
潤滑 Lubrication	合成潤滑油脂 / Synthetic Lubrication Grease							
噪音值 Noise Level (nl=3000rpm, 無負載)	58 dB							
防護等級 Degree of Gearbox Protection	IP65							
安裝方向 Mounting Position	任意方向 /Any Direction							
重量 Weight ±3%	2.2 kg							

MODEL : VG98 SERIES

1-Stage (Ratio: 3~10)

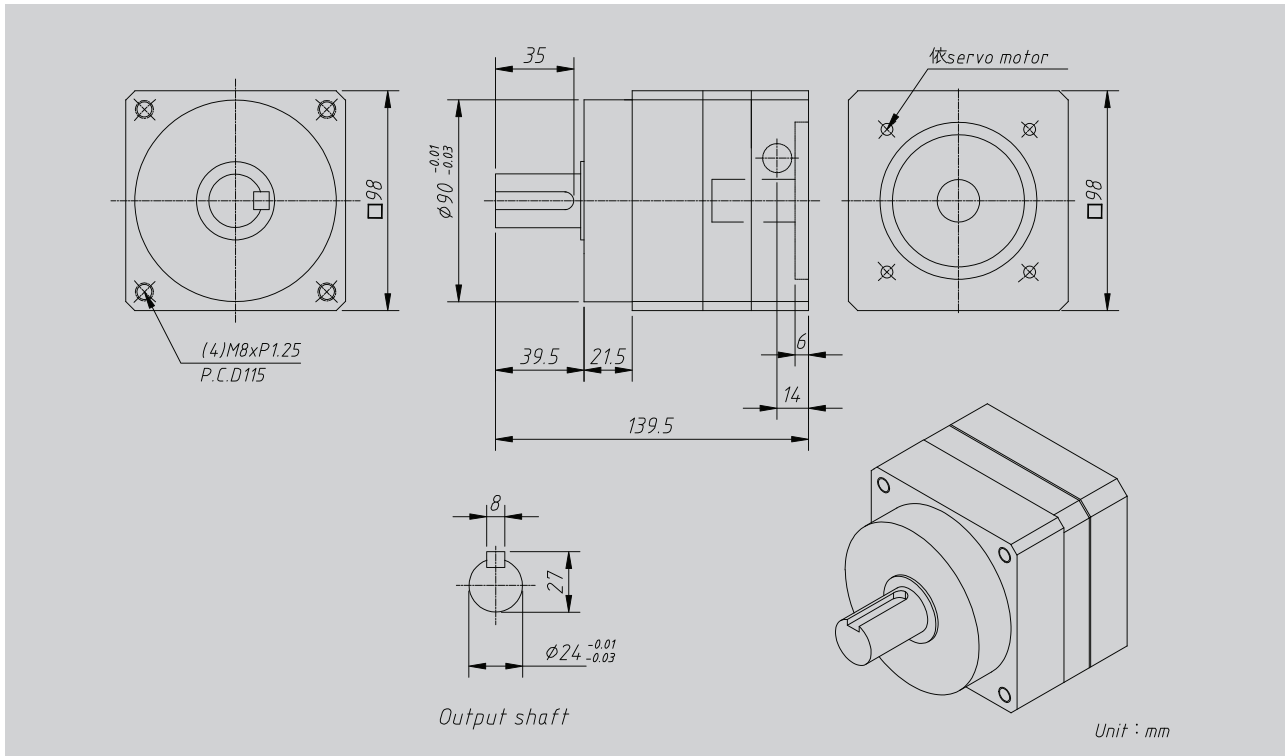
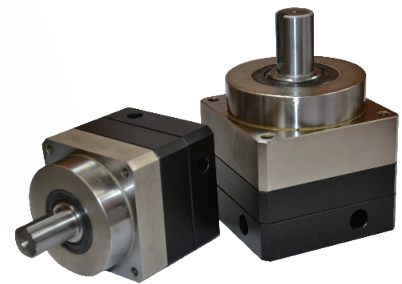

減速比 Ratio	3	4	5	6	7	8	9	10
額定輸出力矩 Nominal Output Torque (N.m)	130	140	160	150	148	142	145	141
最大輸入轉速 Max. input Speed	8000 rpm							
額定輸入轉速 Nominal input Speed	4000 rpm							
標準背隙 Standard Backlash	≤ 7 arcmin							
急停扭矩 Emergency Stop Torque	3 倍額定輸出力矩 / 3Time Of Nominal Output Torque							
扭轉剛性 Torsional Rigidity	14 Nm							
容許徑向力 Max. Radial Force	3230 N							
容許軸向力 Max. Axial Force	1615 N							
使用壽命 Service Life	20000 hr							
使用溫度 Operating Temp	-25°C ~ 90°C							
效率 Efficiency	≥ 97%							
潤滑 Lubrication	合成潤滑油脂 / Synthetic Lubrication Grease							
噪音值 Noise Level (nl=3000rpm, 無負載)	60 dB							
防護等級 Degree of Gearbox Protection	IP65							
安裝方向 Mounting Position	任意方向 / Any Direction							
重量 Weight ±3%	4.2 kg							