

SGL SERIES

產品特點 Product Features

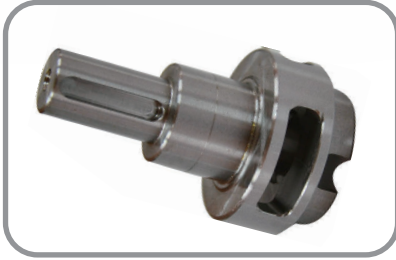

行星臂架與輸出軸採一體式的設計結構，確保最大耐扭力剛性及穩定性。
Integrated design of planet carrier and output shaft ensures the maximum torque stiffness and stability.



輸入端與馬達的連結機構，採用筒夾式的鎖緊經動力平衡分析，以確保在高輸入轉速下結合介面同心度和零背隙的動力傳遞。
Triple split collet with dynamic balanced set collar clamping system provides backlash free power transmission and eliminates slippage. 100% concentricity allows for smooth rotation and higher input speed capability.

齒輪箱和內環齒輪採一體式設計，結構緊湊、精密度高、輸出扭矩大。
Gear box and internal ring gear are integrated designed, diameter maximized, high precision and high torque capacity are specialties.

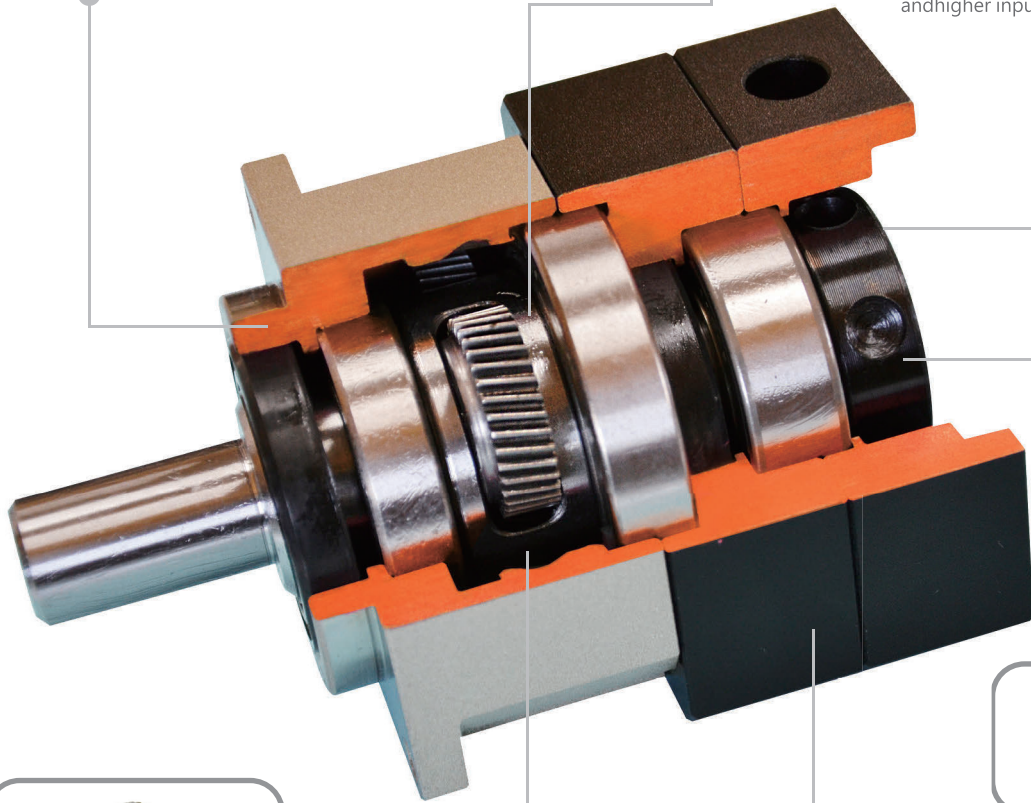

減速機構採螺旋齒輪設計，齒形嚙合率為一般正齒輪的二倍以上，具有運轉平順、低噪音高輸出扭矩和低背隙的特性。
Adopting helical gear design, the contact ratio of planetary reducer is twice higher than vertical one. Smooth running, high output torque and low backlash are distinguished features.

齒輪材質選用鉻鉬釩合金鋼，經調質熱處理至基材硬度 HRC25 度，在利用氣體氮化方式將齒輪表面硬度提昇至 600HV，以獲得最佳的耐磨耗及耐衝擊韌性。
To gain the best abrasion performance and impact resistance · Chromium Molybdenum Vanadium Alloy steel is selected as raw material. Accompany with quenching and tempering heat treatment process · the core hardness is increased to 25 HRC. Accompany with plasma nitriding heat treatment process · the surface hardness is increased to 600 HV.



馬達連接板和襯套採模組化設計，適用於任何廠牌、型式的伺服馬達。
Motor adapter and bushing module are modularized designed · which applied to types of servomotors.

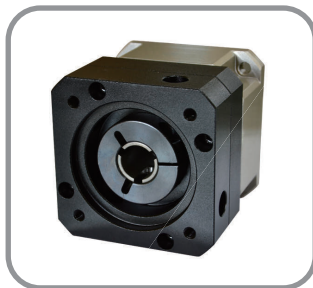

減速機性能資料 Reducer Performance Information

規格 Model NO.	單位 Unit	節數 Stage	減速比 Ratio	42	60	90	115	142	180
額定輸出力矩 T_{2N} Rated Output Torque	Nm	L1	3	21	57	135	216	352	603
			4	20	52	145	298	552	1065
			5	23	62	165	338	660	1215
			6	21	57	155	318	610	1115
			7	20	52	145	308	560	1115
			8	18	47	125	268	510	1015
			9	15	42	105	238	460	915
			10	15	42	105	238	460	915
			15	21	57	135	216	352	603
			20	20	52	145	298	552	1065
		25	23	62	165	338	660	1215	
		30	21	57	155	318	610	1115	
		35	20	52	145	308	560	1115	
		40	18	47	125	268	510	1015	
		50	23	62	165	338	660	1215	
		60	21	57	155	318	610	1115	
		70	20	52	145	308	560	1115	
		80	18	47	125	268	510	1015	
		90	15	42	105	238	460	915	
100	15	42	105	238	460	915			
最大輸入轉速 n_{1B} Max. Input Speed	rpm	L1/L2	3~100	10,000	10,000	8,000	8,000	6,000	6,000
額定輸入轉速 n_{1N} Rated Input Speed	rpm	L1/L2	3~100	5,000	5,000	4,000	4,000	3,000	3,000
標準背隙 Backlash	arcmin	L1	3~10	≤ 8					
		L2	15~100	≤ 12					
最大加速扭矩 T_{2B} Max. Acceleration Torque	Nm	L1/L2	3~100	1.8倍額定輸出力矩 / 1.8 Times of nominal output torque					
最大輸出(急停)扭矩 T_{2NOT} Max. Output(Emergency Stop)Torque	Nm	L1/L2	3~100	3倍額定輸出力矩 / 3 Times of nominal output torque					
扭轉剛性 Torsional Rigidity	Nm/arcmin	L1/L2	3~100	3	7	14	25	50	145
容許徑向力 F_{2rB} Max. Radial Force	N	L1/L2	3~100	780	1,530	3,250	6,700	9,400	14,500
容許軸向力 F_{2aB} Max. Axial Force	N	L1/L2	3~100	390	765	1,625	3,350	4,700	7,250
使用壽命 Service Life	hr	L1/L2	3~100	S5週期運轉 > 20,000 ; (S1連續運轉 > 10,000 hrs) S5 Cycle Operation ; > 20,000 (S1 Continuous Operation ; > 10,000 hrs)					
使用溫度 Operation Temperature	°C	L1/L2	3~100	-25°C ~ 90°C					
效率 η Efficiency	%	L1	3~10	≤ 97					
		L2	15~100	≤ 94					
潤滑 Lubrication		L1/L2	3~100	合成潤滑油脂 / Synthetic Lubrication Grease					
噪音值 Noise Level	dB	L1	3~10	≤ 56	≤ 60	≤ 63	≤ 63	≤ 65	≤ 67
		L2	15~100	≤ 56	≤ 60	≤ 63	≤ 63	≤ 65	≤ 67
防護等級 Protection Class	IP	L1/L2	3~100	IP 65					
安裝方向 Mounting Position		L1/L2	3~100	任意方向 / Any direction					
重量 Weight	kg	L1	3~10	0.5	1.2	3.5	7.5	15.5	38
		L2	15~100	0.8	1.8	5.2	11.2	22.5	48

減速機轉動慣量 Reducer Moment of inertia

規格 Model NO.	單位 Unit	節數 Stage	減速比 Ratio	42	60	90	115	142	180
轉動慣量 J_1	kg.cm ²	L1	3	0.03	0.16	0.61	3.25	9.21	28.98
			4	0.03	0.14	0.48	2.74	7.54	23.67
			5	0.03	0.13	0.47	2.71	7.42	23.29
			6	0.03	0.13	0.45	2.65	7.25	22.75
			7	0.03	0.13	0.45	2.62	7.14	22.48
			8	0.03	0.13	0.44	2.58	7.07	22.59
			9	0.03	0.13	0.44	2.57	7.04	22.53
			10	0.03	0.13	0.44	2.57	7.03	22.51
			15	0.03	0.03	0.13	0.47	2.71	7.42
			20	0.03	0.03	0.13	0.47	2.71	7.42
		25	0.03	0.03	0.13	0.47	2.71	7.42	
		30	0.03	0.03	0.13	0.47	2.71	7.42	
		35	0.03	0.03	0.13	0.47	2.71	7.42	
		40	0.03	0.03	0.13	0.47	2.71	7.42	
		50	0.03	0.03	0.13	0.44	2.57	7.03	
		60	0.03	0.03	0.13	0.44	2.57	7.03	
		70	0.03	0.03	0.13	0.44	2.57	7.03	
		80	0.03	0.03	0.13	0.44	2.57	7.03	
		90	0.03	0.03	0.13	0.44	2.57	7.03	
		100	0.03	0.03	0.13	0.44	2.57	7.03	

MODEL : SGL SERIES

1-Stage (Ratio:3~10)

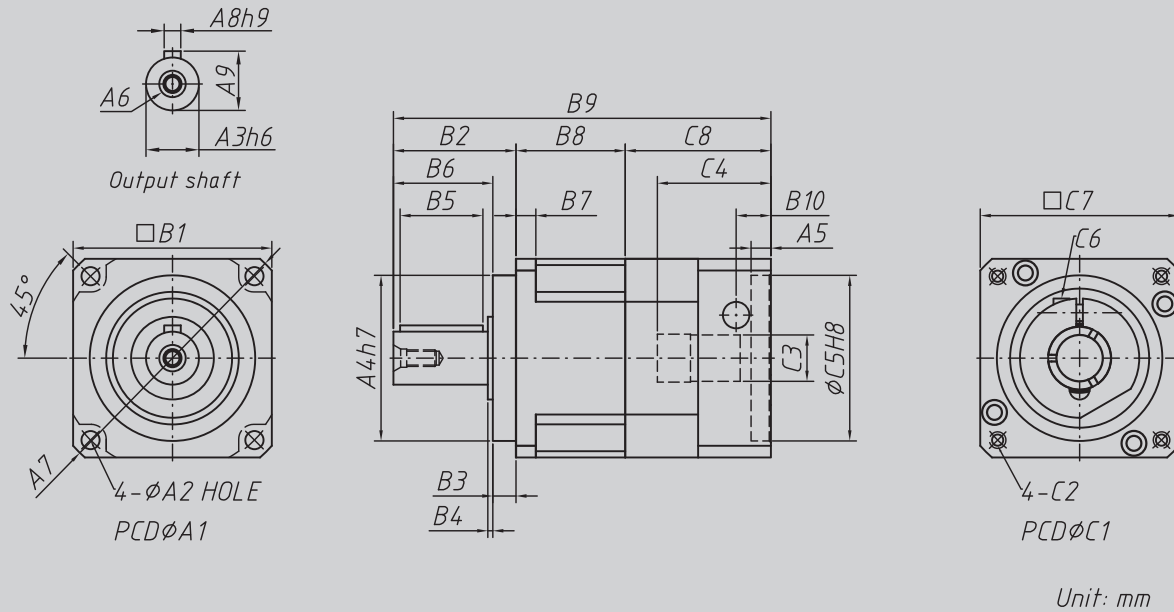
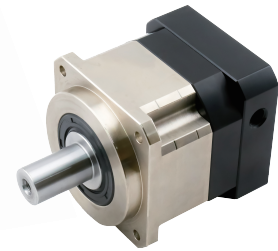

Model Code	42	60	90	115	142	180
A1	50	70	100	130	165	215
A2	3.5	5.5	6.5	8.5	10.5	13.5
A3	13	16	22	32	40	55
A4	35	50	80	110	130	160
A5	6	6	7.5	22.5	11	12
A6	M4 x P0.7	M5 x P0.8	M8 x P1.25	M12 x P1.75	M16 x P2.0	M20 x P2.5
A7	56	80	116	148	185	240
A8	5	5	6	10	12	16
A9	15	18	24.5	35	43	60
B1	42.6	60	90	115	142	180
B2	26	37	48	65	97	104.5
B3	5.5	7	10	12	15	20
B4	1.6	1.5	1.5	2	3	2.5
B5	15	25	30	40	63	70
B6	20.5	30	38	53	82	84.5
B7	4	6	8	10	12	16
B8	28.3	33	43	54	72	87.5
B9	88.65	114	138	190	251	292
B10	11	13.5	14	15	23	27.5
C1	46	70	90	145	165	200
C2	M4 x P0.7	M5 x P0.8	M6 x P1.0	M8 x P1.25	M10 x P1.5	M12 x P1.75
C3	8	14, 19	19, 24	24, 28	35, 42	42
C4	26	34	43	67.5	68	72.5
C5	30	50	70	110	130	114.3
C6	M3 x P0.5	M5 x P0.8	M6 x P1.0	M8 x P1.25	M10 x P1.5	M12 x P1.75
C7	42.6	60	90	130	142	180
C8	34.35	44	47	71	82	100

MODEL : SGL SERIES

2-Stage (Ratio:15~100)

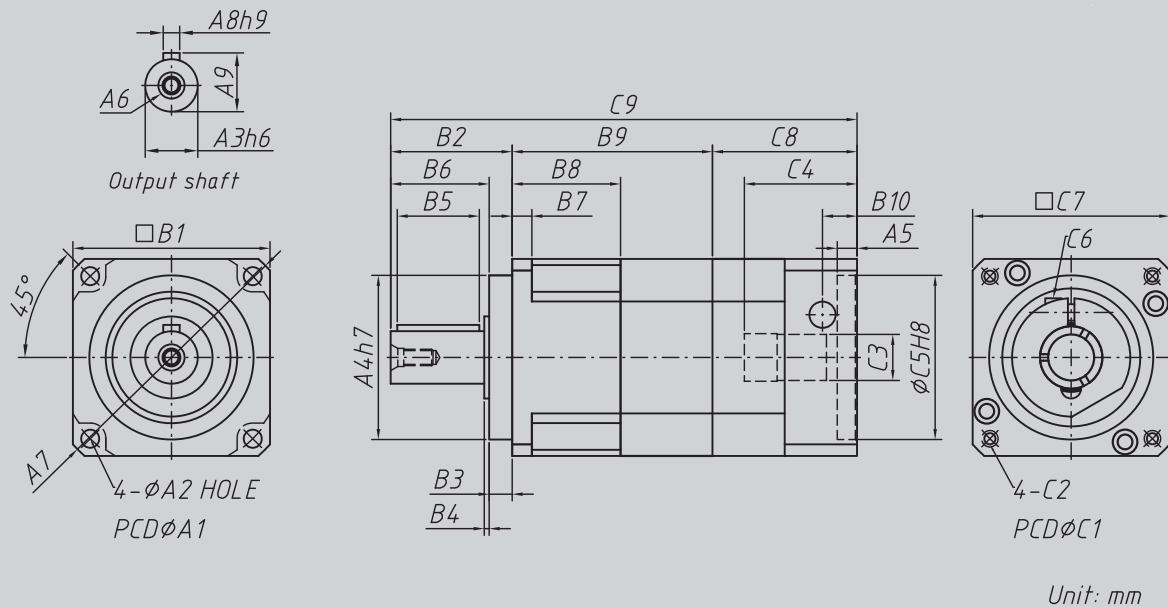

Model Code	42	60	90	115	142	180
A1	50	70	100	130	165	215
A2	3.5	5.5	6.5	8.5	10.5	13.5
A3	13	16	22	32	40	55
A4	35	50	80	110	130	160
A5	6	6	7.5	22.5	11	12
A6	M4 x P0.7	M5 x P0.8	M8 x P1.25	M12 x P1.75	M16 x P2.0	M20 x P2.5
A7	56	80	116	148	185	240
A8	5	5	6	10	12	16
A9	15	18	24.5	35	43	60
B1	42.6	60	90	115	142	180
B2	26	37	48	65	97	104.5
B3	5.5	7	10	12	15	20
B4	1.6	1.5	1.5	2	3	2.5
B5	15	25	30	40	63	70
B6	20.5	30	38	53	82	84.5
B7	4	6	8	10	12	16
B8	28.3	33	43	54	72	87.5
B9	54.3	61	83	102	123	177.5
B10	11	13.5	14	15	23	27.5
C1	46	70	90	145	165	200
C2	M4 x P0.7	M5 x P0.8	M6 x P1.0	M8 x P1.25	M10 x P1.5	M12 x P1.75
C3	8	14, 19	19, 24	24, 28	35, 42	42
C4	26	34	43	67.5	68	72.5
C5	30	50	70	110	130	114.3
C6	M3 x P0.5	M5 x P0.8	M6 x P1.0	M8 x P1.25	M10 x P1.5	M12 x P1.75
C7	42.6	60	90	130	142	180
C8	34.35	44	47	71	82	100
C9	114.65	142	178	238	312	382